



RS-SERIES

300W/ 350W/400W

450W/550W/650W



TECHNICAL DETAILS & SPECIAL FEATURES

EXTREMELY HIGH EFFICIENCY

Up to 85% of efficiency, compliant with 80-PLUS® efficiency requirement .

ACTIVE POWER FACTOR CORRECTION (ACTIVE PFC)

PF value up to 99%, provides clean and reliable power

COMPATIBLE WITH LATEST PC-TECHNOLOGY

Supports the newest specifications of ATX12V

Created for usage with current and next-generation multi-core CPU platforms.

HIGHEST DURABLE & RELIABLE JAPANESE CAPACITORS

The best solution for a High-End PSU by using Japanese capacitors, Japanese capacitors provide uncompromised performance and reliability.

ULTRA-QUIET & TEMPERATURE-CONTROLLED FAN

Extremely Low Noise Level, equipped with a large and ultra-quiet 120mm fan.

INTEGRATED AIR INLET DESIGN

Optimal air-dynamical design, lead to more silent operation

DYNAMIC DUAL 12V

Automatic dynamic load distribution on dual 12V line to provide power separately to the GPU and the CPU. If you are not using all output lines, the PSU automatically reroutes needed power from unused lines. This improves the performance of the 12V lines considerably for systems with high-end graphics cards in SLI® or CrossFire® mode, and provide high voltage stability to keep components safe.

ALL IN ONE CABLE

SATA and MOLEX-Connector on one cable, provides neat and convenient installation

COMPLIANT WITH LATEST EUROPEAN DIRECTIVE 2009/125/EC (ErP)

Energy consumption in Standby is < 0.5W, compliant with economy-friendly electrical equipment.

FULL PROTECTIONS WITH OCP, SCP, OVP, UVP, OPP



80 PLUS CERTIFICATION

Up to 85% of efficiency, compliant with 80-PLUS® efficiency requirement .

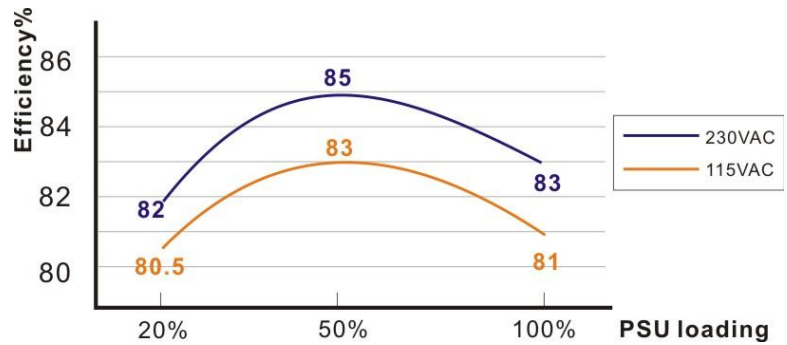

ULTRA-QUIET & TEMPERATURE-CONTROLLED FAN

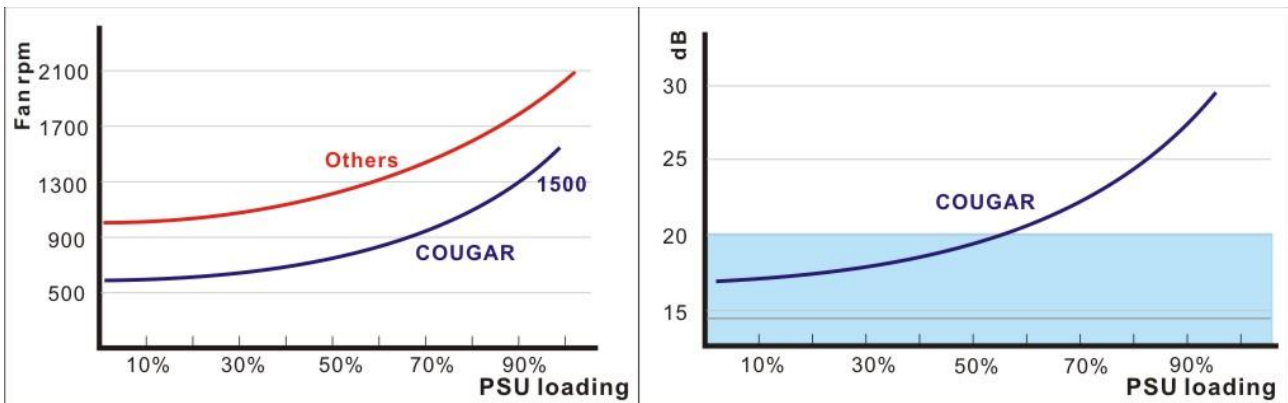

All PSUs of the COUGAR® RS-series are equipped with quiet 120mm fan(super low voltage & super low RPM), which adapts its rotating speed to the PSU temperature. Even on its highest rotating level the fan is still quiet enough to be barely noticeable.

SPECIFICATION

RATING

Item Name	Input Characteristics			Output Characteristics						
	Voltage	Frequency	Input Current	+3.3V	+5V	+12V1	+12V2	-12V	+5Vsb	Total output
RS300 CGR R-300	AC100- 240	50-60Hz	5A	21A	15A	11A	14A	0.3A	2.5A	300W
103W				228W						
RS350 CGR R-350			6A	21A	15A	14A	14A	0.3A	2.5A	350W
103W				276W						
RS400 CGR R-400			8A	24A	15A	20A	20A	0.3A	2.5A	400W
120W				384W						
RS450 CGR R-450			8A	24A	15A	22A	20A	0.3A	2.5A	450W
120W		420W								
RS550 CGR R-550	10A	24A	15A	28A	20A	0.3A	3A	550W		
120W		480W								
RS650 CGR R-650	10A	24A	15A	30A	20A	0.3A	3A	650W		
130W		528W								



CABLES & CONNECTORS

Model	Main connector	CPU connector	Floppy connector	Peripheral connector	S-ATA connector	PCI-E 6pin	PCI-E 6+2pin
RS 300	1	4+4	1	3	4	1(adapter)	0
RS 350	1	4+4	1	3	4	1	0
RS 400	1	4+4	1	3	4	1	0
RS 450	1	4+4	1	3	5	1	0
RS 550	1	4+4	1	4	6	1	1
RS 650	1	4+4 & 8	1	4	6	1	1

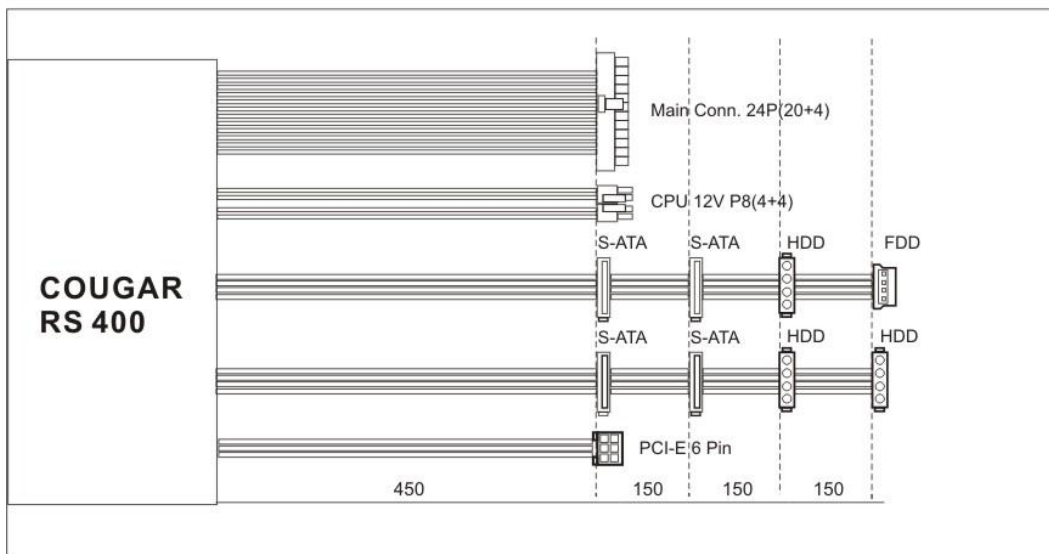
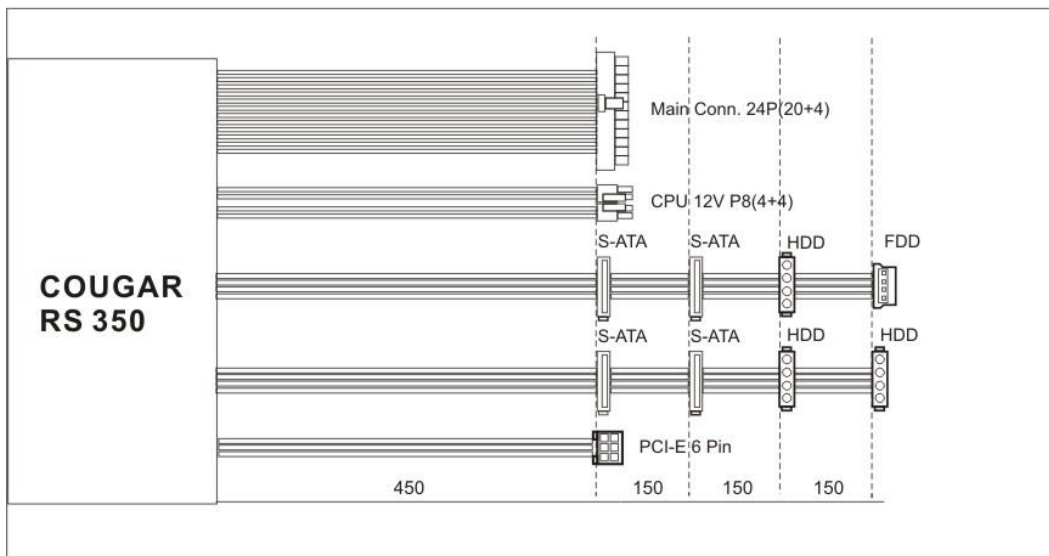
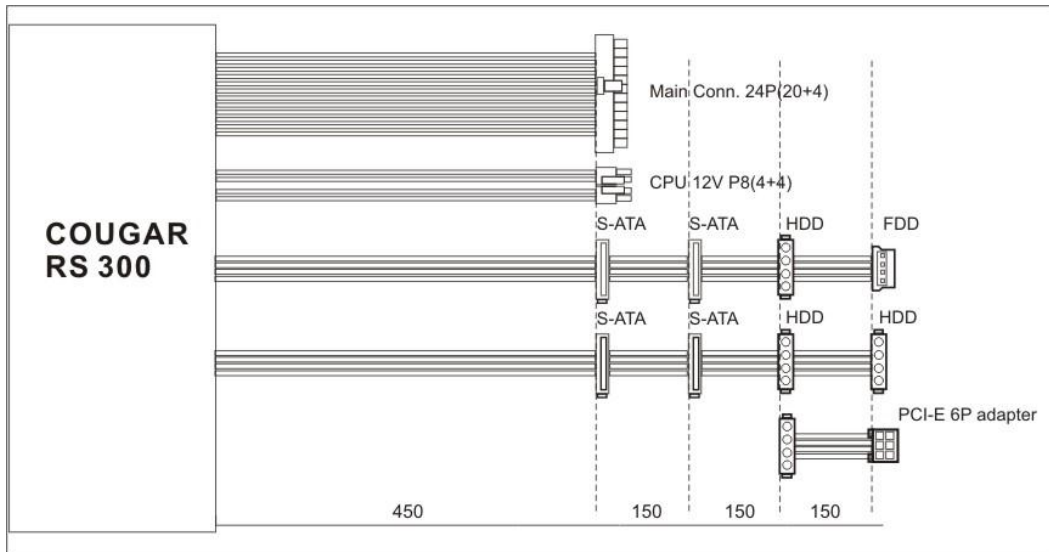

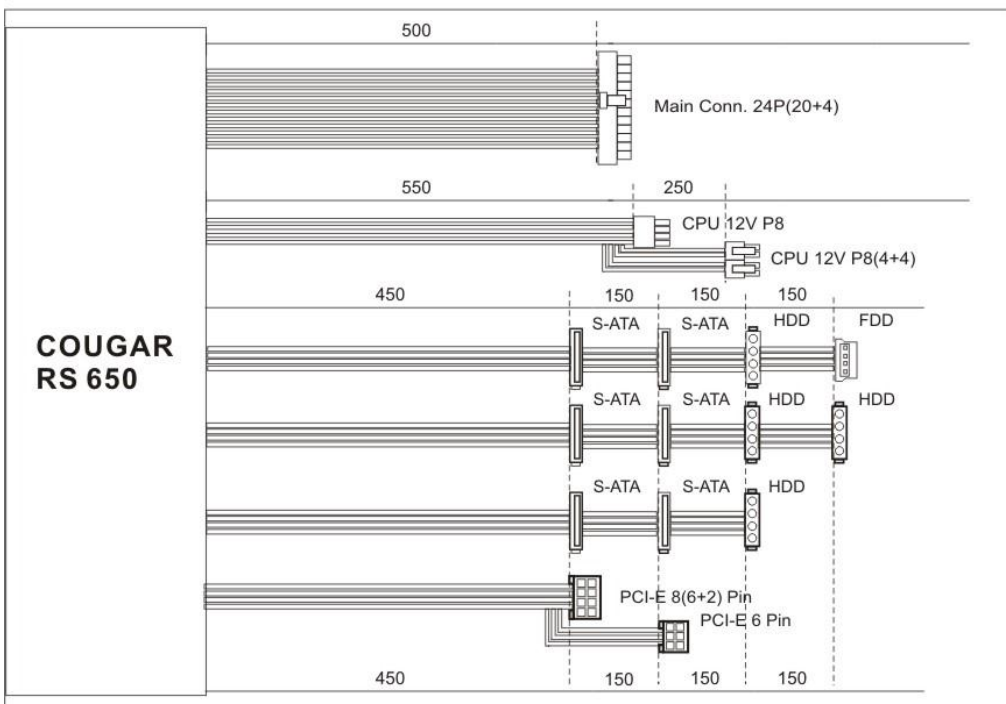
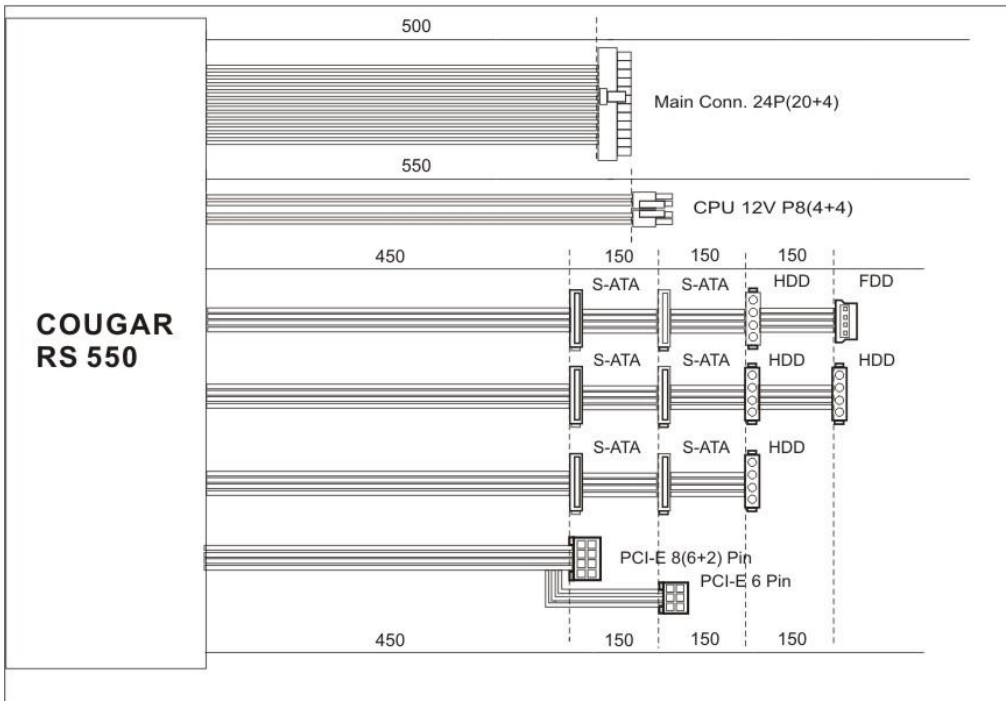
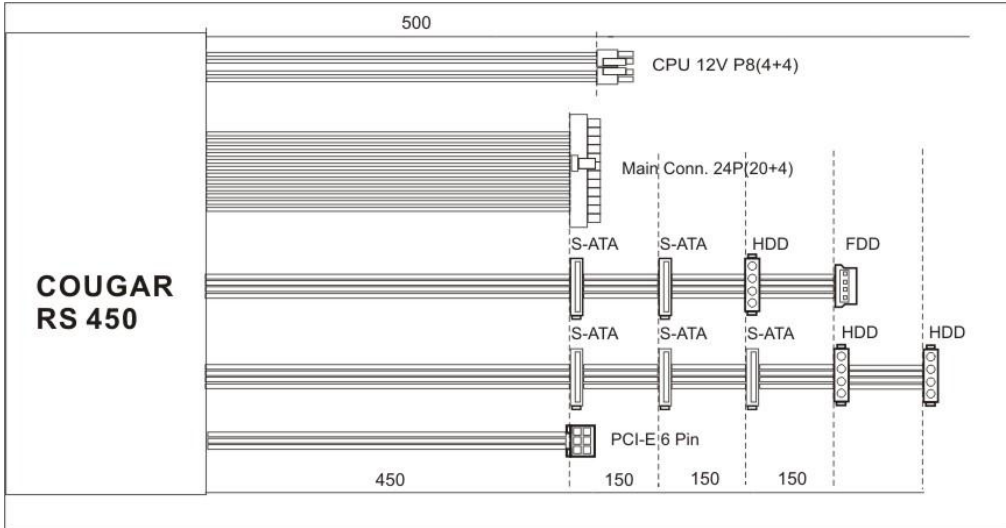



DIMENSIONS

Dimension (L*W*H) mm	140 x 150 x 86
----------------------	----------------

SAFETY FUNCTIONS

UVP (Undervoltage protection)

If the voltages fall below a certain tolerance value on the single lines, the PSU automatically switches off.

OVP (Overvoltage protection)

If the voltages increase above a certain tolerance value on the single lines, the PSU automatically switches off.

SCP (Short-circuit protection)

In the case of a short-circuit this feature prevents damage to the core components of the PSU and its system components.

OPP (Overload protection)

If the system is oversized and requires more power from the PSU than it can perform, this protection function is activated.

OCP (Overcurrent protection)

If the load on a single line is higher than indicated, the PSU automatically switches off.

SAFETY & EMI CERTIFIED:

